

Temperature sensor and FAN controller

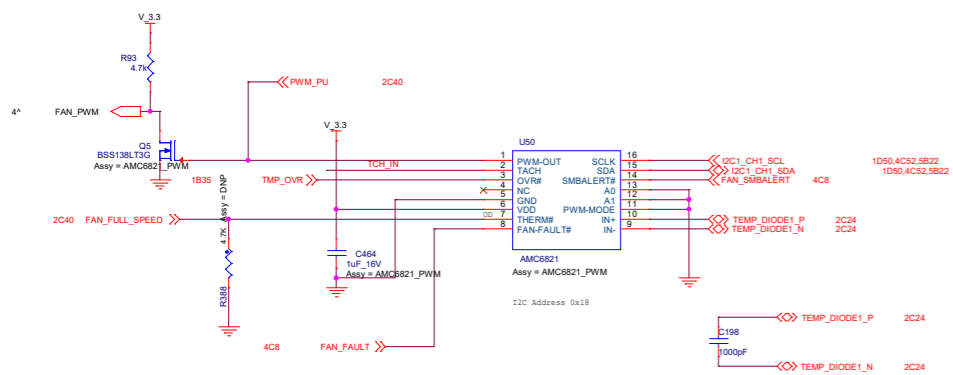

Secondary temperature sensor

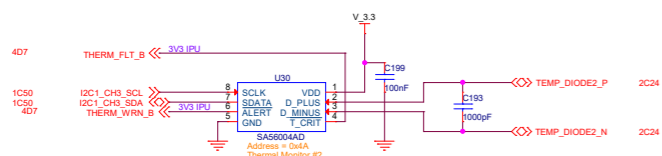

Two MDC/MDIO controllers

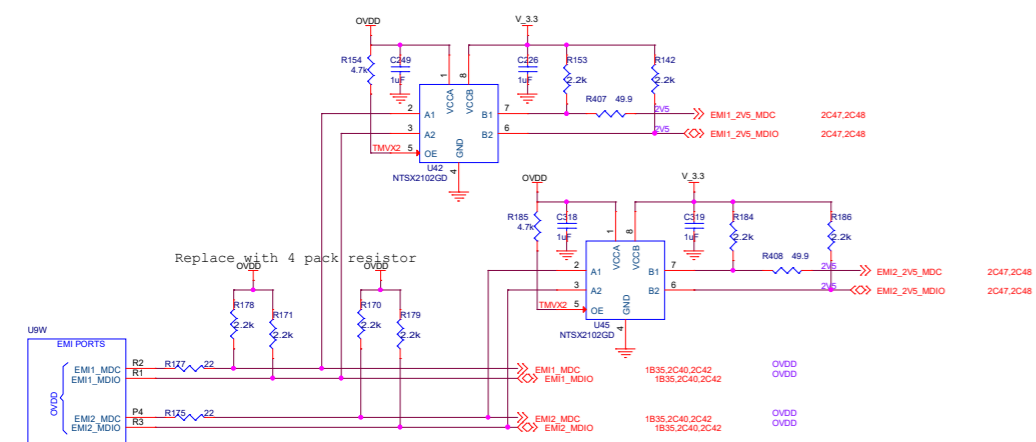

Two USB 3.0 controllers configured as host

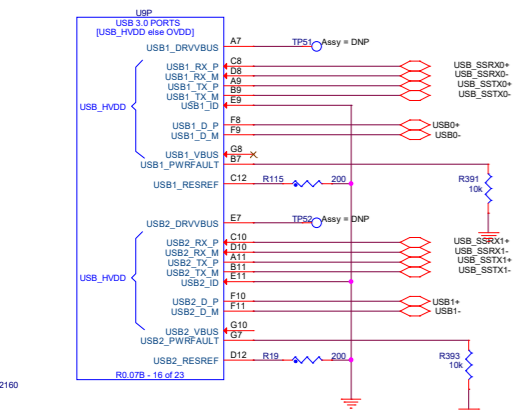

SD controller

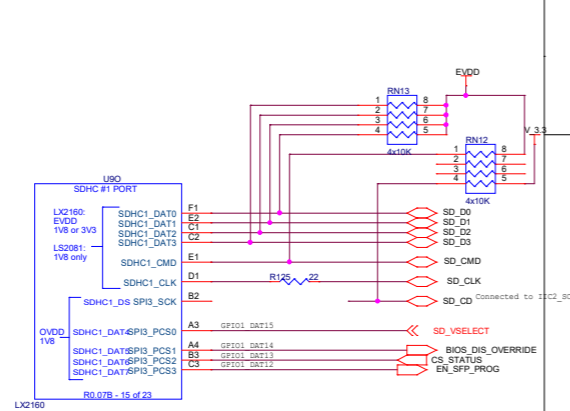

2Mb I2C eeprom and RTC clock

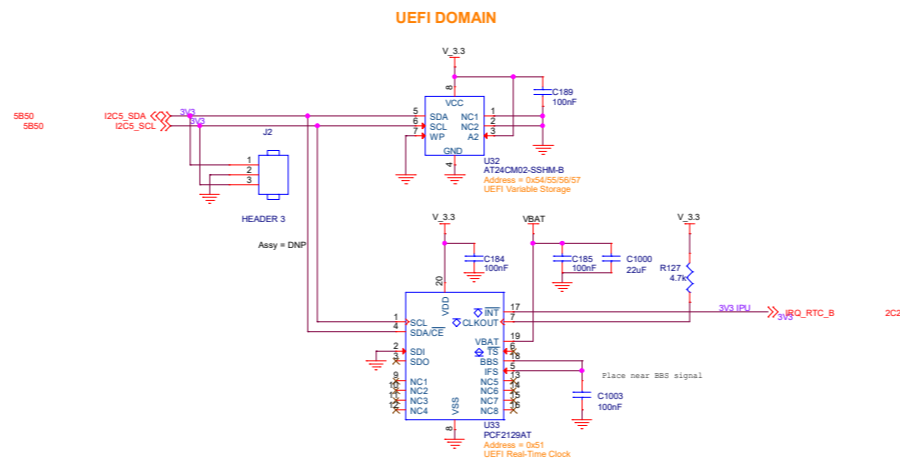

512Kb bootable I2C eeprom, 2Kb variables i2c eeprom and header

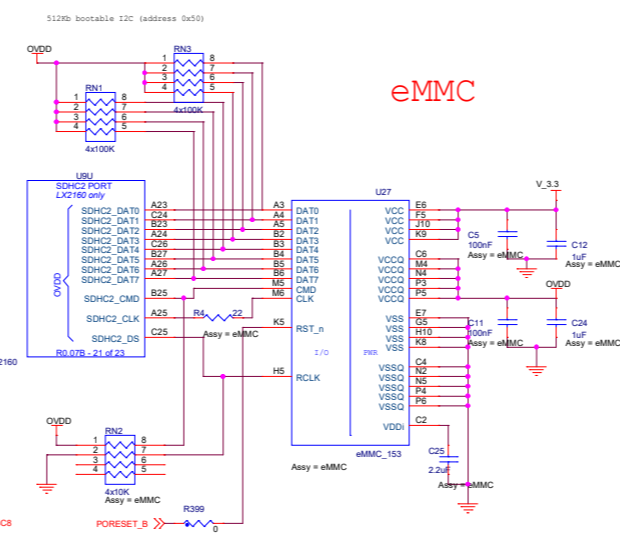
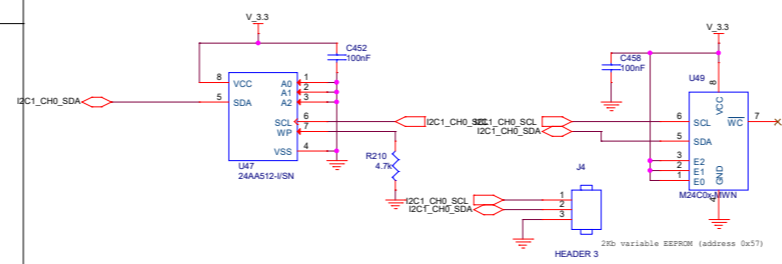

3.3v voltage indication LED

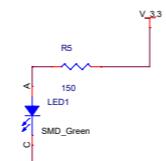

SERIAL UART 0 and 1

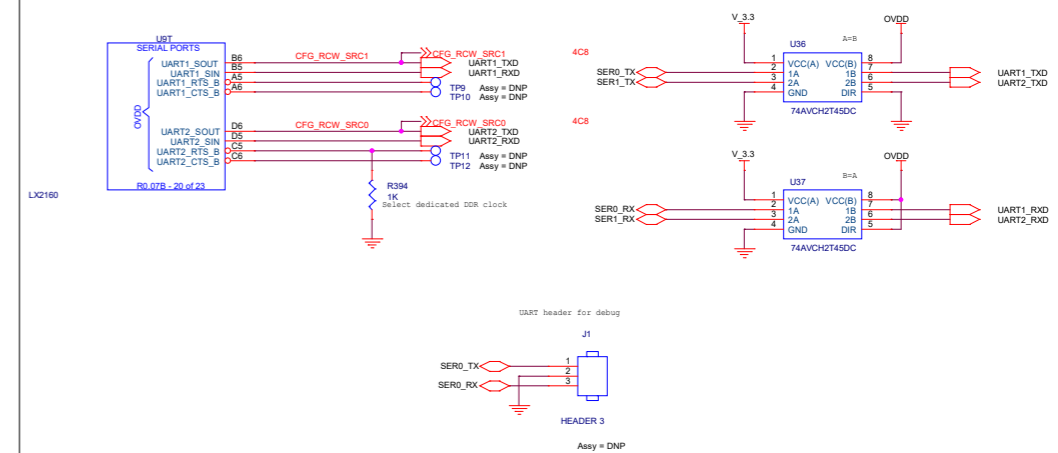

I2C controllers and MUX

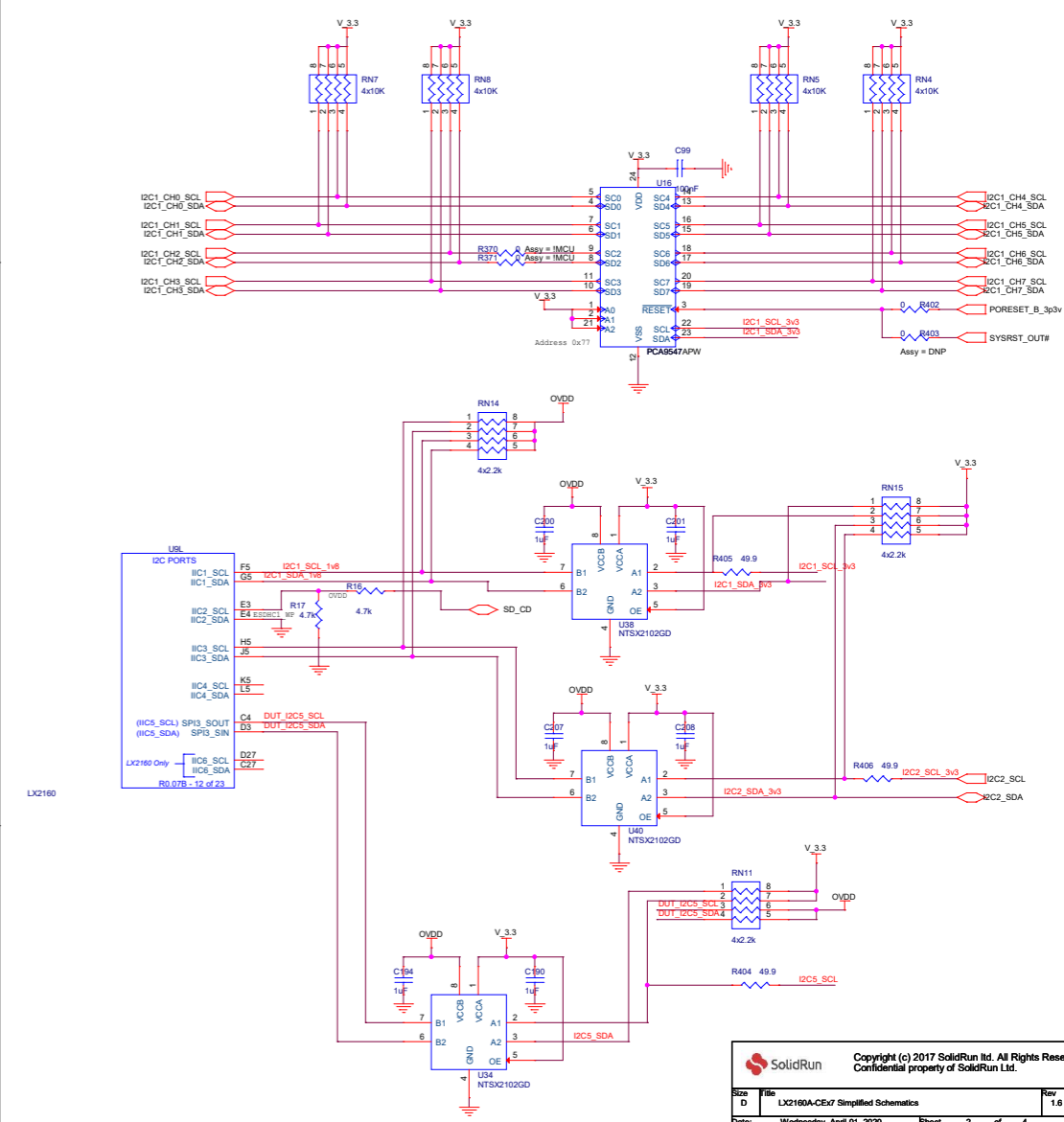

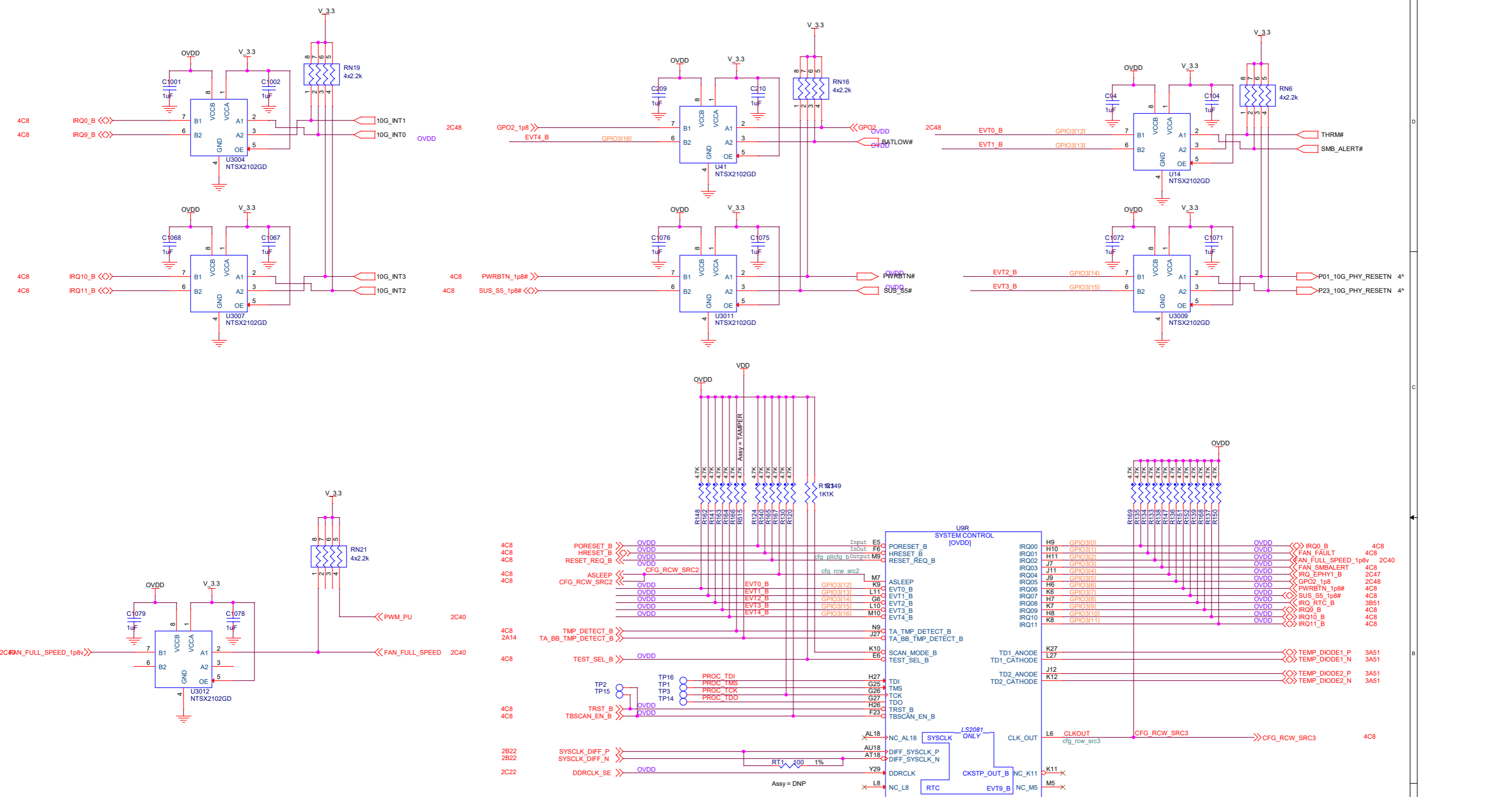

USB 3.0 hub

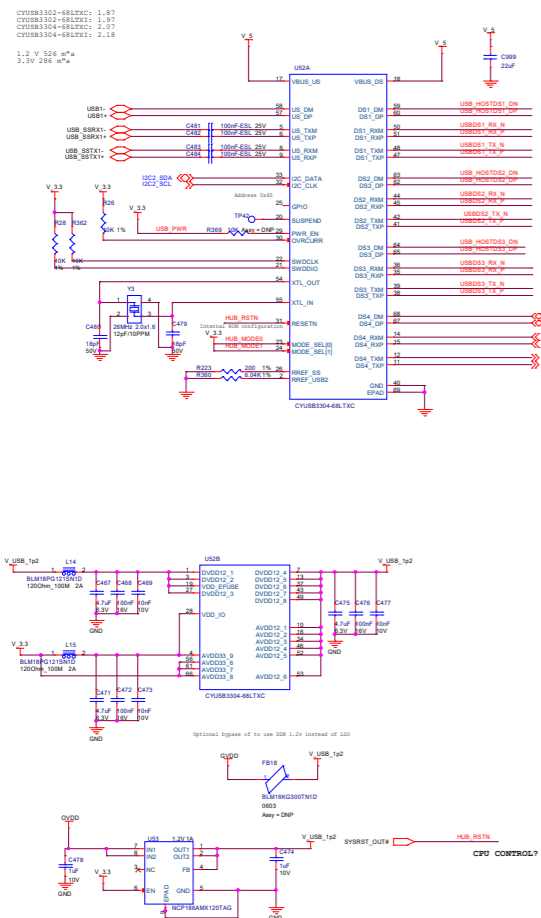

1Gbps Ethernet copper

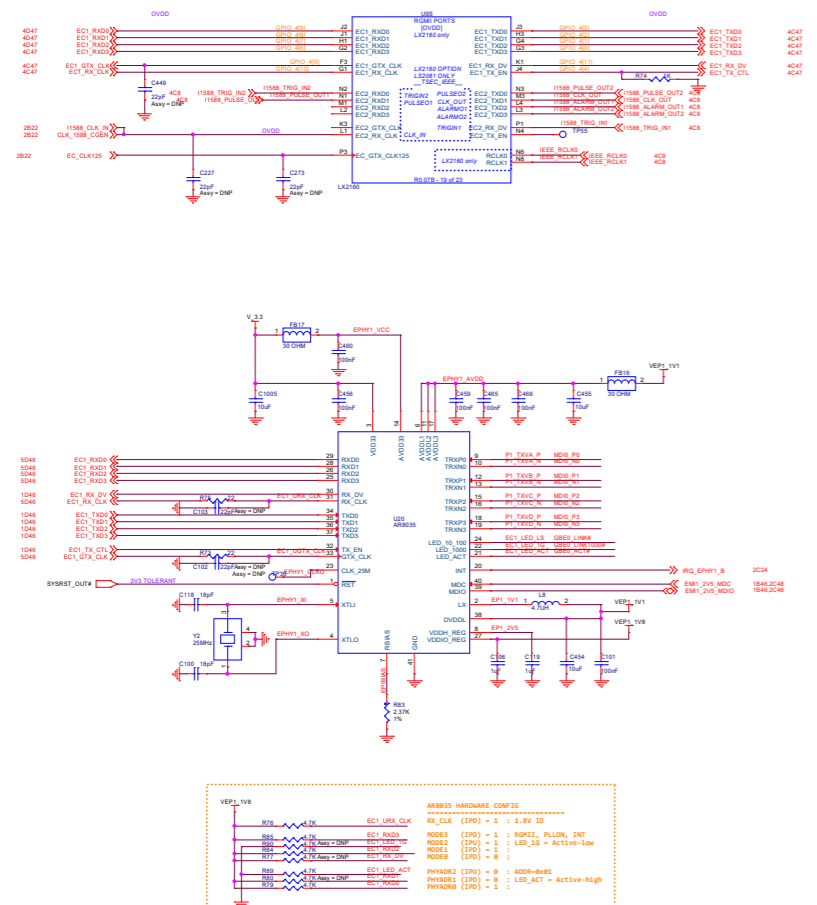

Mechanical holes

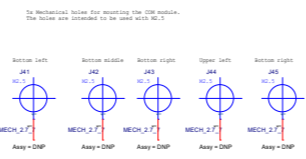

COM Express type 7 A/B

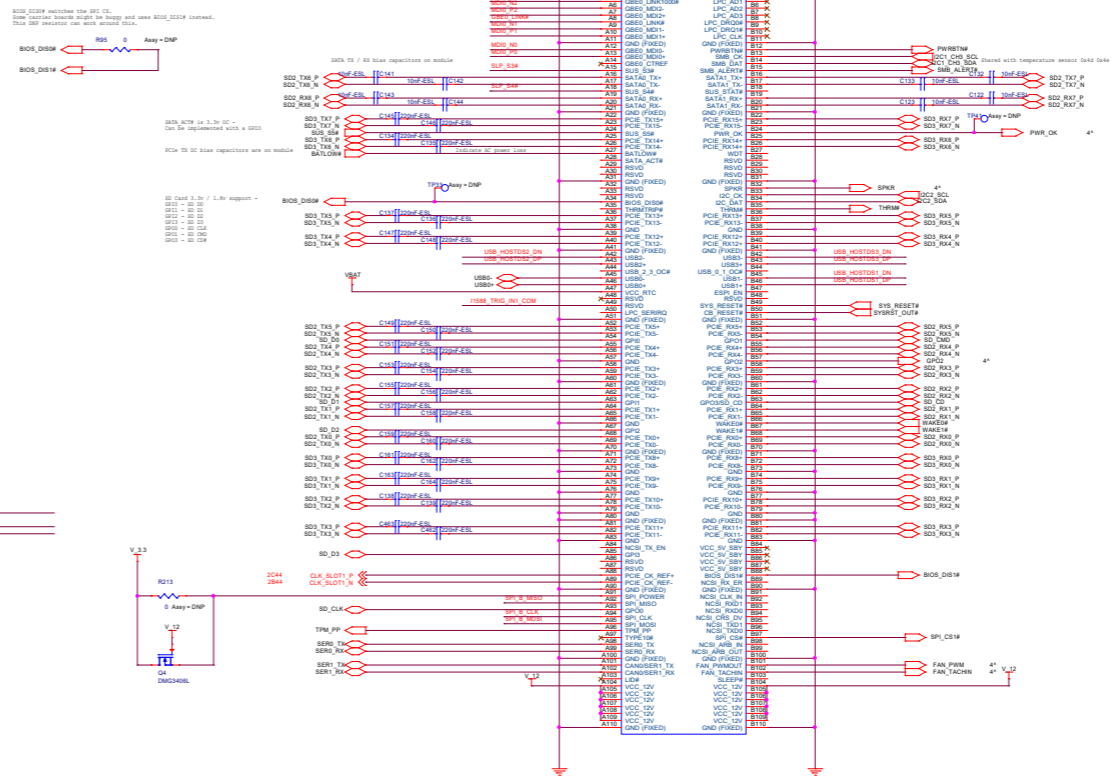

COM Express type 7 C/D

